

ADJUSTABLE CHOKE VALVE



Specification:

COP's Adjustable choke assembly is furnished with alloy steel stem and seat as standard trim for regular or standard services. Choke valve is a lubricated, tapered seal, quarter-turn plug valve for rapid full open or close operation. The valve cavity is tapered to ensure uniform of the sealing stems, providing a reliable seals at the full range of pressures.

- Type: Adjustable
- Body design: Angle type
- End Connection: 2" LP Inlet/outlet.
- Design Pressure: 2000 PSI CWP & 3000 PSI CWP
- Trim Size: 3/4" on 2000 PSI and 1" on 3000 PSI
- Trim Material: Alloy Steel 4130
- Grease fittings on Adjustable Model bonnets
- Easy to read indicator in 64th inch
- Low Maintenance

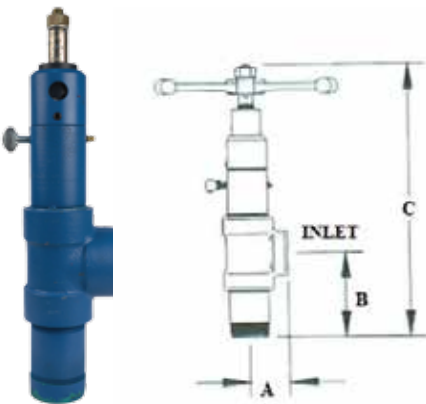

CHOKE2-2M-ADJ-TRIM3/4



CHOKE2-3M-ADJ-TRIM1

Model #	Inlet	Outlet	Working Pressure	Trim Size	A	B	C
CHOKE2-2M-ADJ-TRIM3/4	2" LP	2" LP	2000 psi	3/4"	2.38"	5.31"	16.31"
CHOKE2-3M-ADJ-TRIM1	2" LP	2" LP	3000 psi	1"	2.50"	7.44"	22.50"

* Due to the continuous development of our products, design or construction may change without prior notice.

ADJUSTABLE CHOKE VALVE



CHOKE2-2M-ADJ-TRIM3/4

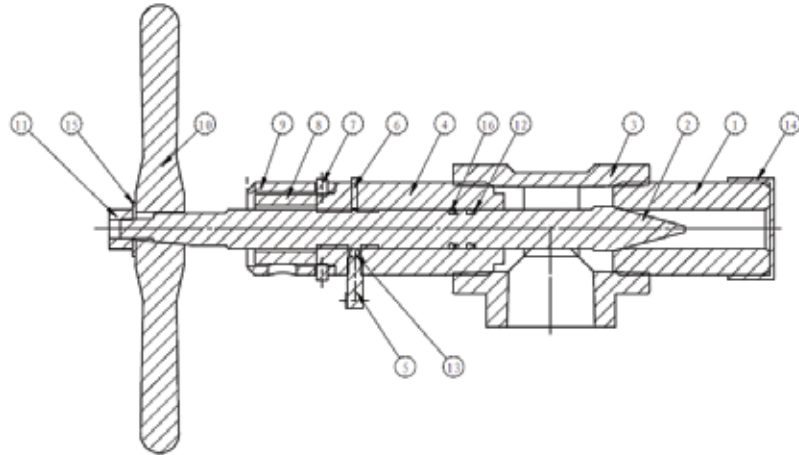

16	18.64X3.53 "O" RING	2	NBR
15	1/2"GASKET	1	Carbon Steel
14	2"LP RHREAD SMART COVER	1	Plastic
13	NYLON BALL	1	Nylon
12	19.46X3 BACK-UP RING	2	PTFE
11	1/2"-13UNC NUT	1	Carbon Steel
10	HAND WHEEL	1	NODULAR
9	SHIELD	1	AISI 1045
8	INDICATOR	1	NYLON
7	5/16"-18UNCX9.5 SET SCREW	2	Carbon Steel
6	M6 OIL CUP	1	Carbon Steel
5	3/8"-16UNC THUMBSCREW	1	Carbon Steel
4	SCREW NUT	1	AISI 4130
3	TEE	1	ASTM A105
2	STEM	1	AISI 4130
1	2"LP NIPPLE	1	AISI 4130
NO.	DESCRIPTION	QTY	MATERIAL

Service Maintenance:

Periodic maintenance of your choke will insure proper operation and service life. The choke bonnet is equipped with a grease fitting and should be lubricated periodically to ensure proper stem thread lubrication. Visually inspect the entire choke for evidence of escaping media. Check connections and seal areas and stem packing.

ADJUSTABLE CHOKE VALVE



CHOKE2-3M-ADJ-TRIM1

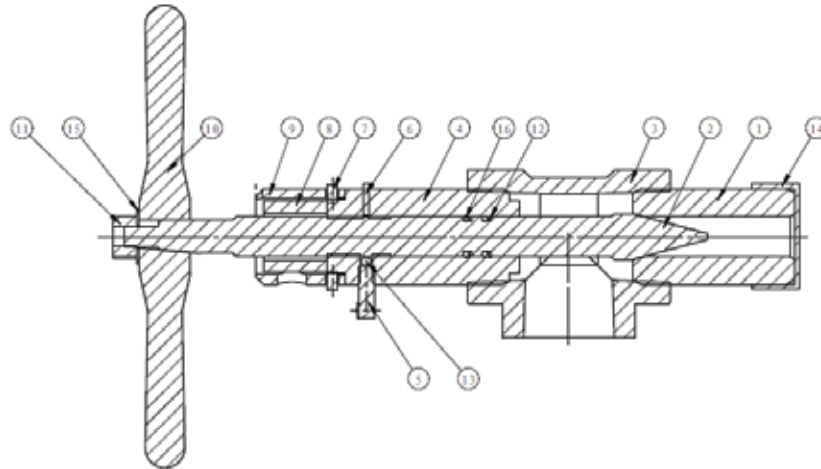

16	18.64X3.53 "O" RING	2	NBR
15	1/2" Washer	1	Carbon Steel
14	2"LP RHREAD SMART COVER	1	Plastic
13	NYLON BALL	1	Nylon
12	19.46X3 BACK-UP RING	2	PTFE
11	1/2"-13UNC NUT	1	Carbon Steel
10	HAND WHEEL	1	NODULAR CAST
9	SHIELD	1	AISI 1045
8	INDICATOR	1	NYLON
7	5/16"-18UNCX9.5 SET SCREW	2	Carbon Steel
6	M6 OIL CUP	1	Carbon Steel
5	3/8"-16UNC THUMBSCREW	1	Carbon Steel
4	SCREW NUT	1	AISI 4130
3	TEE	1	ASTM A105
2	STEM	1	AISI 4130
1	2"LP NIPPLE	1	AISI 4130
NO.	DESCRIPTION	QTY	MATERIAL

Service Maintenance:

Periodic maintenance of your choke will insure proper operation and service life. The choke bonnet is equipped with a grease fitting and should be lubricated periodically to ensure proper stem thread lubrication. Visually inspect the entire choke for evidence of escaping media. Check connections and seal areas and stem packing.